

INSTALLATION INSTRUCTIONS

Rear Vision System – Mirror Display 2007-Current Chevrolet Silverado, Silverado HD; GMC Sierra, Sierra HD (Kit part numbers 9002-9503, without comp/temp and 9002-9504, with comp/temp)

Kit Contents:

- Chassis Harness (longer)
- Mirror Harness (shorter)
- 1 bubble bag containing:
 - Camera/Module/Bezel Assembly
 - Inside Rearview Mirror (ISRVM)
- 1 bag containing:
 - 30 Wire Ties
 - 1 Ground Nut
 - Anti-Corrosion Coating (in a white bottle)
 - Lock Plug (optional)
- 1 bag containing:
 - Jumper Harness
- 1 bag containing:
 - Template (along with these instructions)

Tools Required:

- Socket Wrench
- 10mm and 13mm Sockets
- T15 and T20 Torx Bits
- Torque Wrench
- Trim Removal Tool
- Phillips and Flat Blade Screwdrivers
- Delphi Terminal Tool 12094429 or a small flat blade watch repair screwdriver
- Power Drill
- 25.4mm (1") Hole Saw
- 29mm (1-1/8") Hole Saw
- Deburring Tool
- Center Punch
- Electrical Tape
- Vehicle Hoist

Note: We strive to provide accurate and up-to-date installation instructions. For the latest full color instructions, as well as an installation video, please visit www.brandmotion.com

IMPORTANT: Before beginning kit installation:

- Verify kit contents are complete against list above.
- Please note that Kit 9002-9504, with comp/temp, requires purchasing a 9002-6008 kit (temperature sensor harness). Refer to Kit 9002-9511 instructions posted on www.brandmotion.com for complete installation procedure.
- Also note that vehicles without an auto dimming mirror require purchasing a 9002-6105 kit (mirror harness).

INSTALLATION INSTRUCTIONS

Preparation

1. Ensure all lamps and accessories are OFF.
2. Ensure ignition switch is in the OFF position.
3. Loosen negative battery cable bolt. Remove negative battery cable from terminal and position away from battery.
4. Wait one (1) minute prior to working on vehicle to assure SIR roof rail airbag system has been disabled for your safety.

Install Camera Bezel into Tailgate

5. Lower Tailgate and remove center bezel mounting bolt (1), using 13mm socket. Figure 1.

FIGURE 1

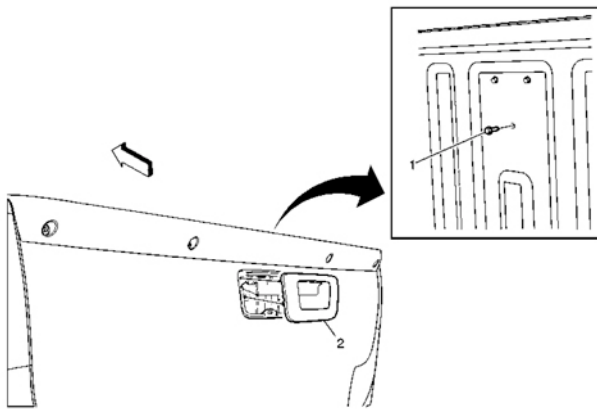

6. Release, by hand, the three retainer clips securing the bezel (2) to the Tailgate outer panel. Lift the Tailgate latch handle in order to aid in the removal of the latch handle bezel. Figure 1.
7. If the Truck is not equipped with Tailgate Lock (&A60), remove the two upper Tailgate Latch Handle Bolts (1) from the Tailgate Latch Handle (2), using 13mm socket. Figure 2. Release Rods before removing (inset). If equipped, skip this step.

FIGURE 2

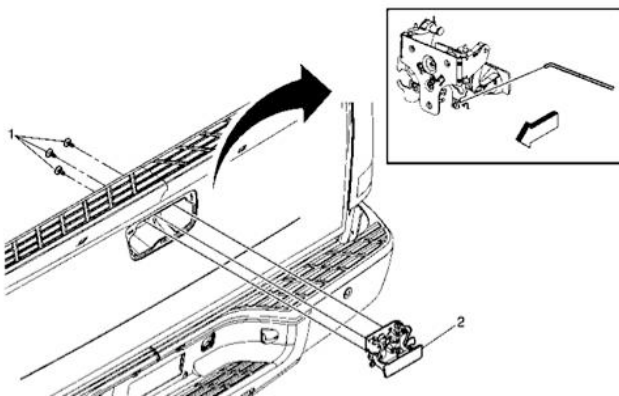

8. Prepare a work surface for the Tailgate, as it will be removed.

9. Disconnect two Tailgate support cables. Figure 3.

FIGURE 3

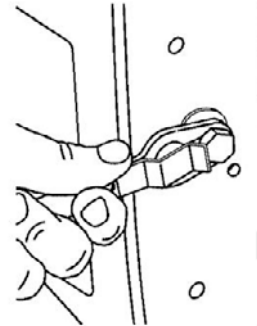

10. With the aid of an assistant, remove the Tailgate and locate to clean work surface. Figure 4.

FIGURE 4

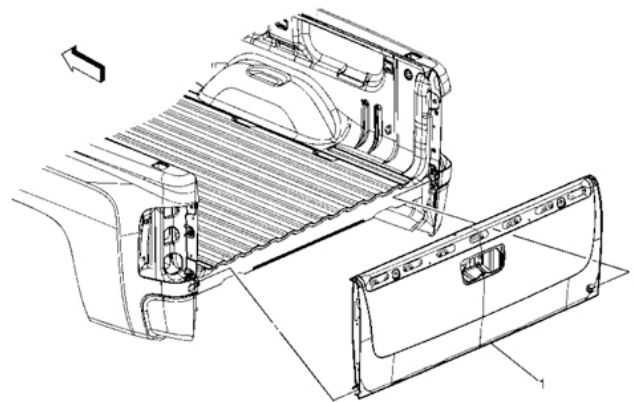

11. Locate the supplied Template Sheet for the Tailgate and Pickup Box Sill.
Note: For Model Year 2009 and forward, some vehicles may already have a flanged hole in the pickup box sill. If this is the case, remove the flange from the front side of the sill and skip steps 13 and 15.
12. Cut out Tailgate Template and attach to Tailgate using tape. Using a Center Punch, mark the center of hole.
13. Cut out Sill Plate Template and attach to Pickup Box Sill using tape. Using a Center Punch, mark the center of hole.
14. Using a power drill and a 29mm (1-1/8") Hole Saw, cut out the harness pass-through in the Tailgate. Figure 5.

FIGURE 5

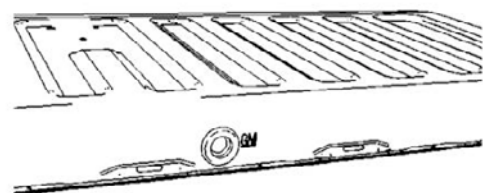

INSTALLATION INSTRUCTIONS

- Using a power drill and a 29mm (1-1/8") Hole Saw, cut out harness pass-through in Pickup Box Sill. Figure 6.

FIGURE 6

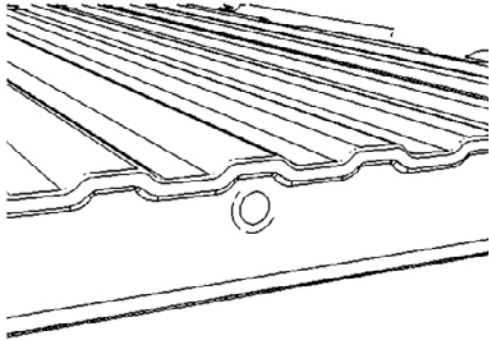

- Clean rough edges using a Deburring Tool.
- Apply supplied Anti-Corrosion Coating to the two cut outs.
- Locate supplied Camera Bezel Assembly. Figure 7.

FIGURE 7



- If Truck is equipped with a factory Tailgate Lock, remove lock cylinder from the original Tailgate Bezel. Remove Tailgate Lock Cylinder Retaining Clip (1) and then Tailgate Lock Cylinder (2). Figure 8.

FIGURE 8

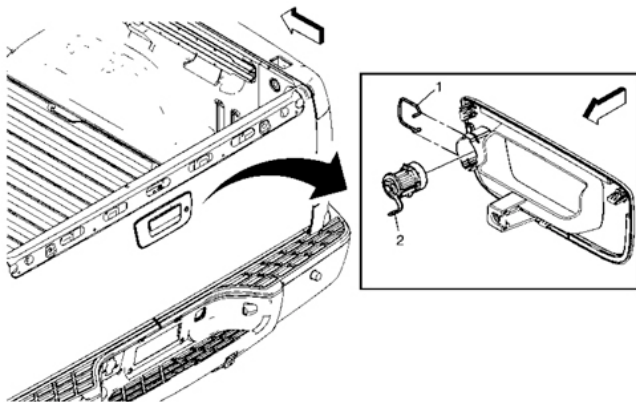

- If equipped, insert the Tailgate Lock Cylinder (2) into the new Tailgate Bezel and re-attach the Tailgate Lock Cylinder Retaining Clip (1). Figure 8.
 - If the Truck is not equipped with factory Tailgate Lock, install supplied Lock Plug.
 - If locking features are desired, a Tailgate Latch Handle (part number 25775280) and a Tailgate Lock Cylinder (part number 25775278) are available through GM dealers.
- Install the new Tailgate Bezel Assembly, by first routing the Camera Assembly harness pigtail through the Tailgate Bezel opening down through the Tailgate to the 29mm hole at the bottom of the Tailgate. Figure 9.

FIGURE 9

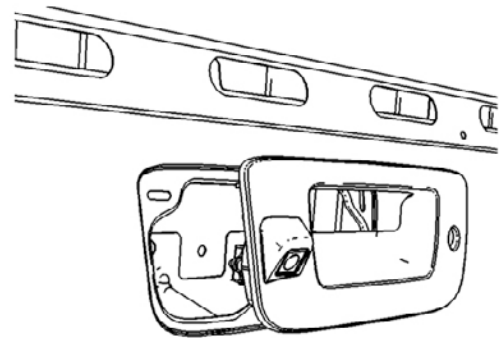

- Pull connector (2), first grommet (3), and second grommet (4) through new Tailgate (1) pass-through. Figure 10.

FIGURE 10

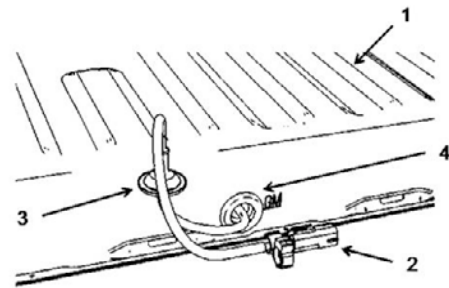

- Snap Tailgate Bezel Assembly into Tailgate.
- Seat second grommet (4) securely around opening. Figure 10.
- Install remaining Tailgate Latch Handle Bolt in Tailgate and tighten all three 13mm bolts to 25 N·m (18 lb ft).
- If present, remove Rear License Plate.
- With the help of an Assistant, re-install the Tailgate onto the Pickup Box, carefully routing the Camera harness through the opening on the Pickup Box Sill.
- Re-attach Tailgate Support Cables and close Tailgate. Figure 11.

INSTALLATION INSTRUCTIONS

FIGURE 11

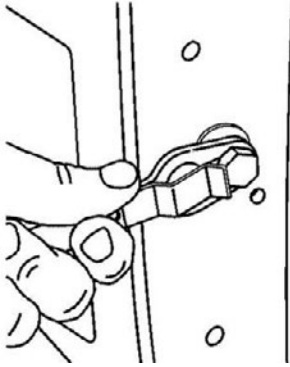

29. Pull the Camera Assembly Harness (2) through License Plate Opening until the first grommet (3) is properly seated in the Pickup Box Sill (1). Figure 12.

FIGURE 12

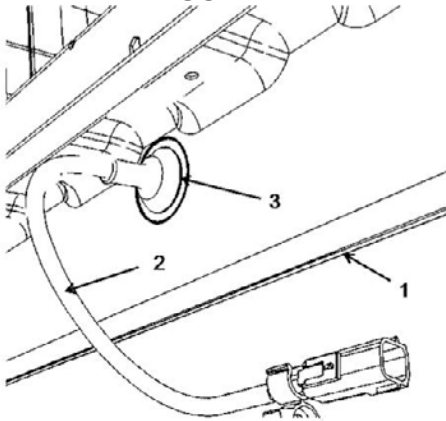

Determine Reverse Signal Location

30. Using a Trim Removal Tool, remove Left Instrument Panel Outer Trim Cover (1). Figure 13.

FIGURE 13

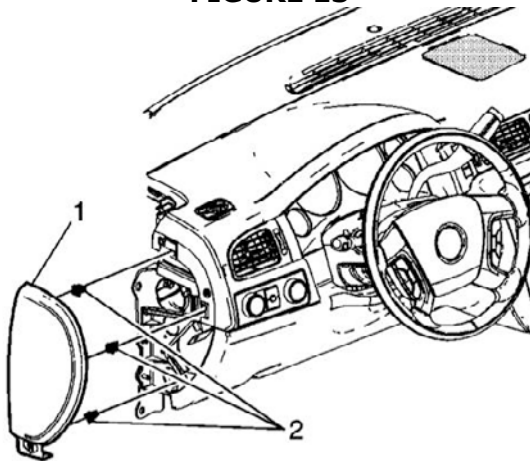

31. Remove M-BEC cover under the dashboard by popping it off with hands. Figure 14.

FIGURE 14



32. Have an assistant set parking brake, start vehicle, and shift into Reverse. Using a digital multimeter, check for reverse signal in Cavity 5 at the Light Gray C11/X11 Connector **OR** Cavity 8 of Gray C10/ X10 Connector in the M-BEC. Figures 15, 16, and 17.

FIGURE 15

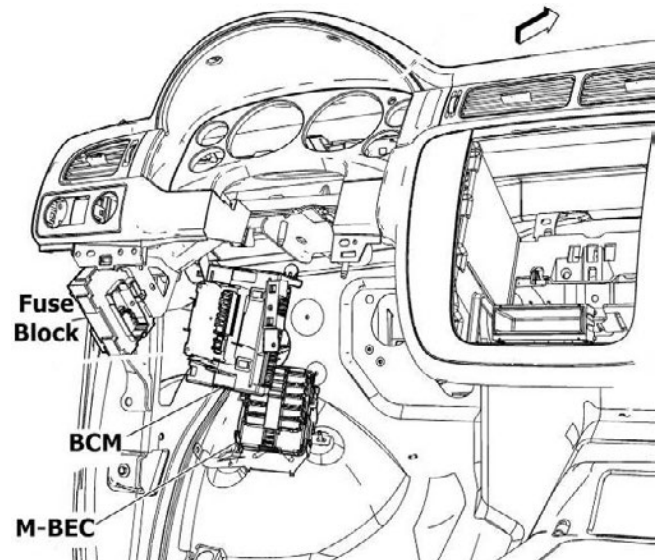
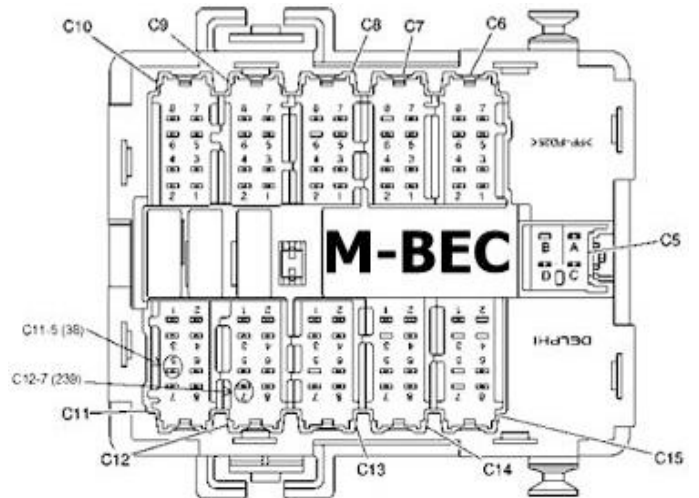
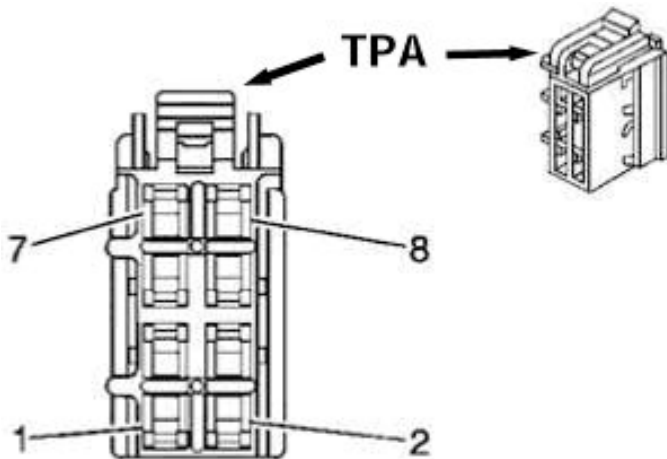

FIGURE 16



INSTALLATION INSTRUCTIONS

FIGURE 17



33. **If reverse signal is NOT present** in the C10/ X10 Connector or C11/ X11 Connector:

- A. Check that bail that secures the M-BEC connectors is fully locked. Repeat Step 33.
- B. If reverse signal is still not present, check Fuse Block for any blown fuses. Figure 15. Replace any blown fuses and repeat Step 33.
- C. **If reverse signal is still NOT present,** connection to reverse signal must be made at the BCM rather than the C10/ X10 or C11/ X11 Connector (refer to Step 67 under "Connect Mirror Harness to Power, Reverse, and Ground").

Cut Accessory Pass-Through in Front of Dash

34. Remove Parking Brake Release Handle Bolt using a 10mm socket and remove Handle. Remove two Knee Bolster Screws (1) using a Phillips screwdriver and remove Knee Bolster (2). Figure 18.

FIGURE 18

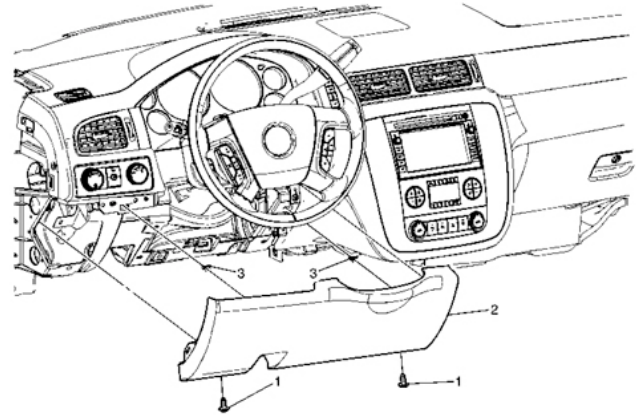

35. Disengage M-BEC (1) from support bracket. Figure 19.

FIGURE 19

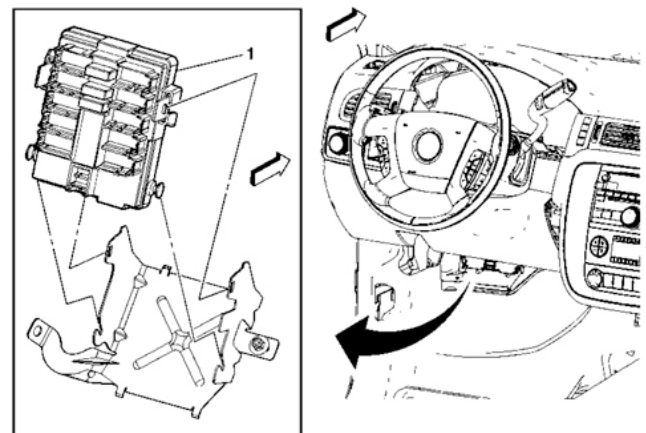

36. Relocate M-BEC up into the IP to gain access to Front-of-Dash Matte Opening behind M-BEC.

37. Locate cut-out in dash matte. Locate the dimple in the sheet metal and then use a center punch to help start a drill bit as close as possible to dimple. Using a power drill and a 25.4mm (1") hole saw, drill out the chassis harness pass-through (2). Figure 20.

INSTALLATION INSTRUCTIONS

FIGURE 20

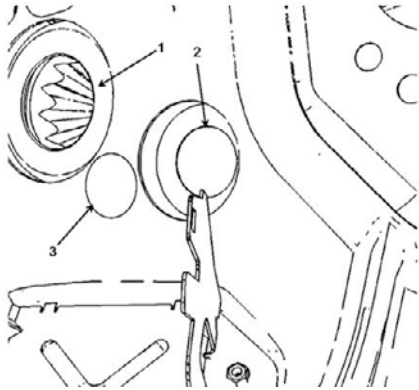

38. If this location is occupied by Trailer Brakes (&JL1) or another Accessory, drill a new Chassis Harness pass-through (3) between the IP Harness (1) and Trailer Brake (2) pass-through grommets. Figure 20
39. Clean rough edges using a Deburring Tool and apply Anti-Corrosion Coating to opening. Figure 21.

Remove Inside Rear View Mirror and Route Supplied Mirror Harness

40. Disengage Inside Rear View Mirror (ISRVM) connector. Figure 21

FIGURE 21

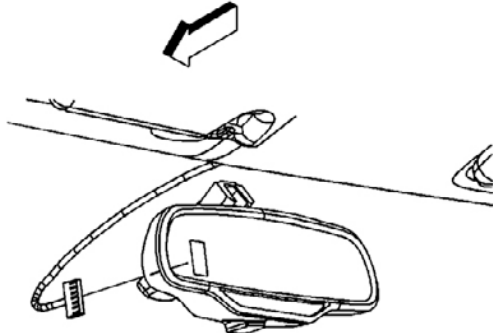

41. Adjust mirror to full upward position.
42. Remove base trim cover, if present.
43. Loosen Screw using a T20 Torx bit (3). Figure 22

FIGURE 22

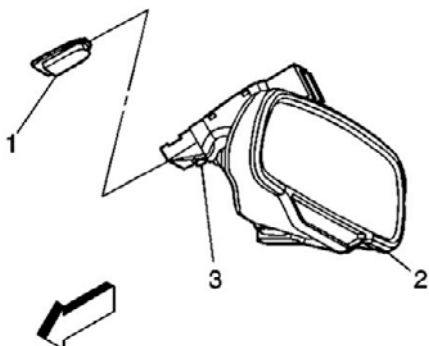

44. Slide the mirror assembly (2) in an upward motion in order to remove and discard. Figure 22.
45. Remove the Wire Cover. Figure 23

FIGURE 23

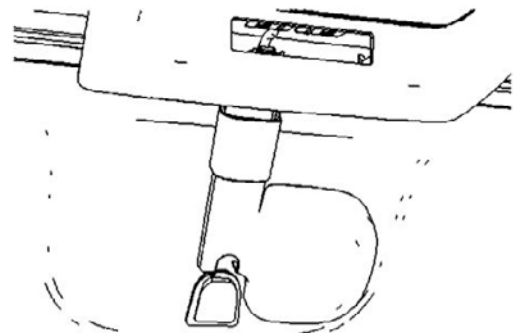

46. Remove the driver's side Windshield Side Garnish Molding Screw Cover (1), Screw (2), and then the Molding Assembly (3). Disconnect the electrical connector. Figure 24

FIGURE 24

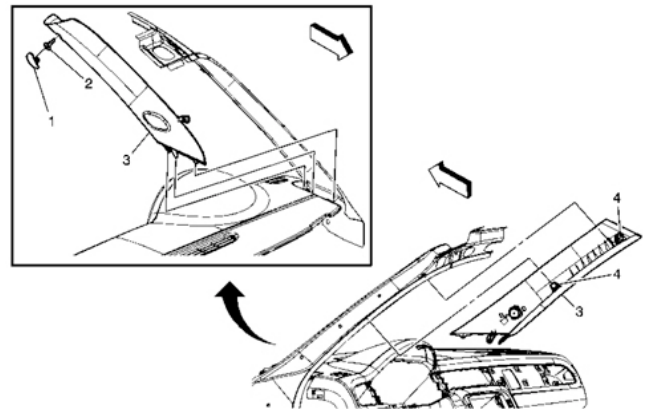

47. Remove Driver's Side Sunshade Bracket Cover (1) and the three Screws (2). Figure 25

FIGURE 25

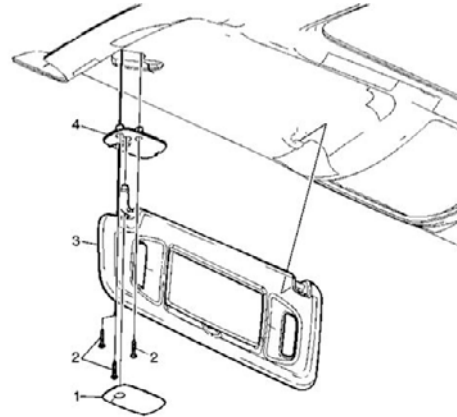

48. Remove Driver's Side Sunshade Assembly (3), electrical connectors, and bracket (4). Figure 25

INSTALLATION INSTRUCTIONS

49. Remove Driver's Side Sunshade Anchor Screw (1) and Anchor (2). Figure 26. (Passenger Side shown).

FIGURE 26

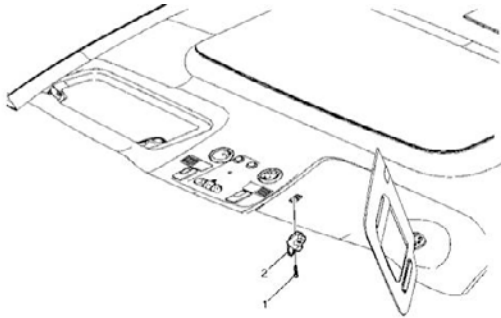

50. Remove Front Overhead Console Lens (1). Figure 27.

FIGURE 27

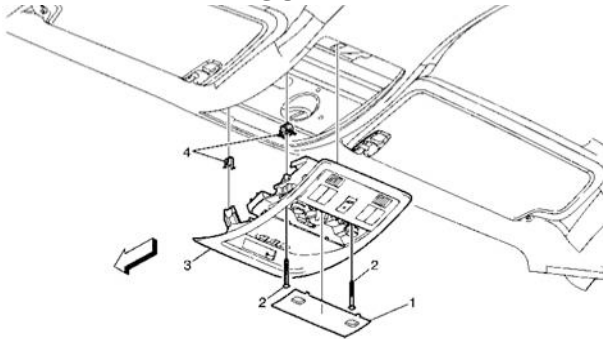

51. Remove two Roof Console Screws (2). Figure 27.
 52. Pull down the Roof Console Assembly (3) to disengage the retainer clips (4). Figure 27.
 53. Disengage Terminal Position Assurance (TPA) device (rectangular white tab) on mirror connector. Use Delphi Terminal Tool 12094429 or a small flat blade watch repair screwdriver to pry up the notches in the TPA. The tab will only lift about 1/10". Figure 28.

FIGURE 28

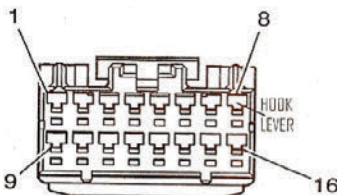

Note: Cavities are numbered on the back side of the mirror connector. Additionally, Brandmotion identifies Cavity 1 with a white mark.

54. Locate the supplied foam wrapped mirror harness.
 55. Insert the Gray/Dark-Blue wire of the mirror harness into the mirror harness connector. Use cavity 1 for Kit 9504 with comp/temp or cavity 6 for Kit 9503. Figure 28.

Note: If a wire exists in this cavity, remove and isolate with electrical tape. Figure 29.

FIGURE 29

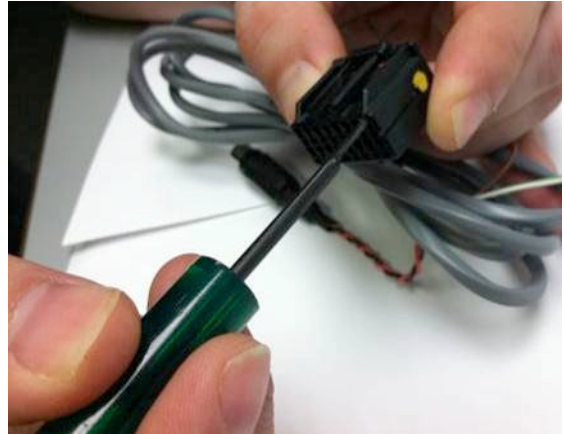

To remove any extra wires, insert the Delphi Terminal Tool or small screwdriver into the hook lever on face of the mirror harness connector and press the selected pin out through the back of connector.

56. Insert the Gray/Orange wire into the mirror harness connector. Use cavity 2 for Kit 9504 with comp/temp or cavity 7 for Kit 9503. Figure 28.
Note: If a wire exists in this cavity, remove and isolate with electrical tape. Figure 29.
57. If your vehicle is not equipped with an auto dimming mirror and wires are not present in cavities 9, 13, or 8, you must purchase a 9002-6105 harness separately from Brandmotion and:
- Insert brown reverse wire (if 6105 harness has a gray jacket) or green reverse wire (if 6105 harness has a black jacket) with terminal from the 6105 harness into cavity 9.
 - Insert green ignition wire (if 6105 harness has a gray jacket) or red ignition wire (if 6105 harness has a black jacket) with terminal from 6105 harness into cavity 13.
 - Insert white ground wire (if 6105 harness has a gray jacket) or black ground wire (if 6105 harness has a black jacket) with terminal from 6105 harness into cavity 8.
 - Splice brown reverse wire (if 6105 harness has a gray jacket) or green reverse wire (if 6105 harness has a black jacket) without terminal from 6105 harness to the green reverse wire from the foam wrapped mirror harness.
 - Splice green ignition wire (if 6105 harness has a gray jacket) or red ignition wire (if 6105 harness

INSTALLATION INSTRUCTIONS

has a black jacket) without terminal from 6105 harness to the pink ignition wire from the foam wrapped mirror harness.

- f. Splice white ground wire (if 6105 harness has a gray jacket) or black ground wire (if 6105 harness has a black jacket) without terminal from 6105 harness to the black ground wire from the foam wrapped mirror harness.
- g. Isolate and tape any unused wires from the 6105 harness.

58. Press down on the TPA device to lock the wires into the mirror harness connector. Figure 28.

59. Route the other end of the supplied mirror Harness down the Driver's Side Instrument Panel near the A-Pillar. Figure 30.

Mirror Harness Pinout			
PIN #	WIRE COLOR	FUNCTION	
		Kit 9002-9503	Kit 9002-9504
1	Gray/ Dark Blue	N/A	Video (+)
2	Gray/ Orange	N/A	Video (-)
3 - 5	N/A	N/A	N/A
6	Gray/ Dark Blue	Video (+)	N/A
6	Varies	N/A	Outside Temperature (+)
7	Gray/ Orange	Video (-)	N/A
7	Varies	N/A	Outside Temperature (-)
8	Black	Ground	Ground
9	Varies	Reverse Signal 12V+	Reverse Signal 12V+
10	N/A	N/A	N/A
11	Varies	OnStar Keypad Output	OnStar Keypad Output
12	Varies	OnStar Keypad Power	OnStar Keypad Power
13	Pink	Ignition Controlled 12V+	Ignition Controlled 12V+
14	Varies	OnStar LED Green	OnStar LED Green
15	Varies	OnStar LED Red	OnStar LED Red
16	N/A	N/A	N/A

FIGURE 30

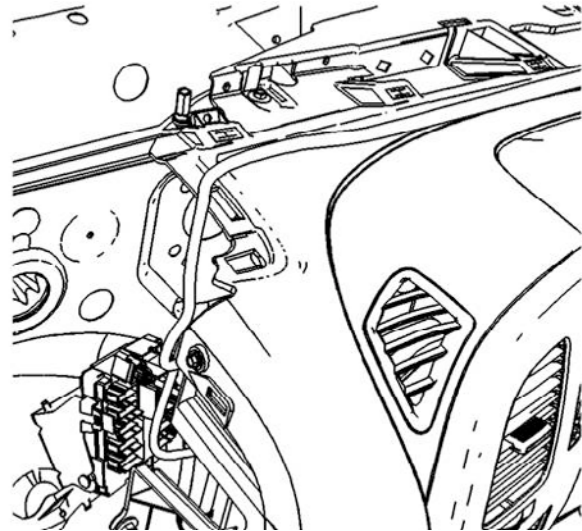

Connect Supplied Mirror Harness to Power, Reverse, and Ground

NOTE: Follow Steps 60-66 only if you located reverse signal at the C10/X10 or C11/X11 M-BEC Connector. If reverse was not present, proceed to Step 67.

60. Remove C12/ X12 Connector (Brown) from the M-BEC. Figure 31.

FIGURE 31



61. Remove the TPA from the C12/ X12 Connector. Figure 17.

62. Connect the pink wire from the supplied mirror harness to C12/ X12 Cavity 7. Figure 28. **NOTE:** Pickups with cooled seats require a Denali Jumper Harness, Brandmotion kit number 9002-6005, available separately.

63. Re-insert TPA and C12/ X12 Connector into M-BEC. Figure 16.

INSTALLATION INSTRUCTIONS

64. Remove the C11/ X11 Connector (Light Gray) or C10/ X10 Connector (Gray) from the M-BEC. Figure 16.
65. Remove the TPA from the C11/ X11 Connector. Figure 17.
66. **If blue wire does not exist in Connector C11/ X11 Cavity 5 or Connector C10/ X10 Cavity 8:**
 - Snap the supplied Jumper Harness into black connector on the supplied mirror harness. Figure 32.

FIGURE 32



- Connect the green wire of the Jumper Harness to cavity 5 of C11/ X11 Connector or cavity 8 of C10/ X10 Connector. Figure 17. Proceed to Step 68.

If blue wire exists in Connector C11/ X11 Cavity 5:

- Unlock the black connector of the supplied mirror harness. Use Delphi Terminal Tool or a small flat blade watch repair screwdriver to slide over the gray TPA device. Figure 33.

FIGURE 33



- Remove the blue wire from cavity 5 of the C11/ X11 connector.
- Insert blue wire into the other cavity of the black connector on the supplied Mirror Harness. Figure 34.

FIGURE 34

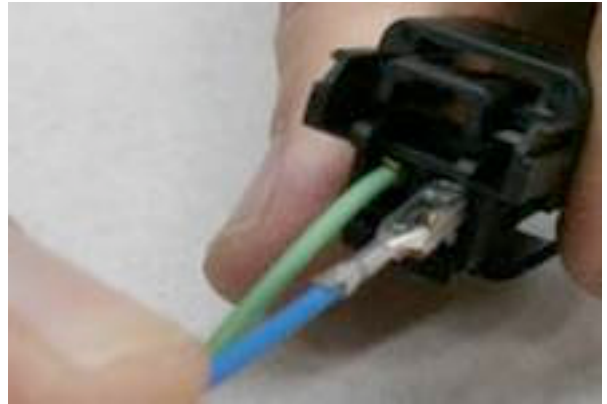

- Use Delphi tool 12094429 or a small flat screwdriver to press the terminal of the blue wire into the connector. Figure 35.

FIGURE 35

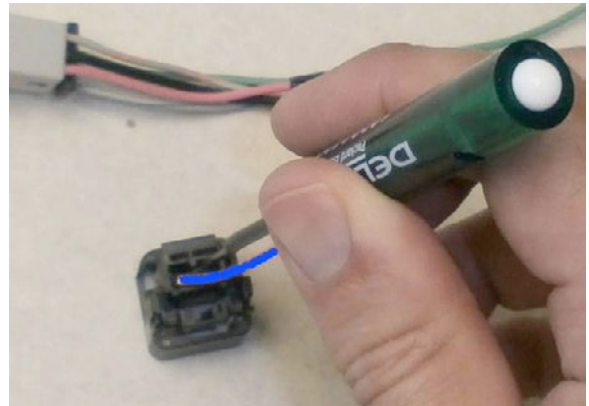

- Slide gray TPA over inside the black connector to lock green and blue wires into place.
- Snap the supplied Jumper Harness into black connector on the supplied mirror harness. Figure 32. Then, connect the green wire of the Jumper Harness to cavity 5 of the C11/ X11 connector (where blue wire was removed). Figure 17.

67. Re-insert TPA and C11/ X11 Connector into M-BEC. Figure 16. Proceed to Step 68.

68. **If all M-BEC connections were secure and no fuses were blown and reverse was still not present,** reverse must be located in the under dash BCM left of the steering wheel. (Figure 15)
 - A. Cut connector off green Reverse (+) wire of supplied Mirror Harness and splice to wire in Brown BCM X5 Connector Cavity 11. Figures 15 & 36.

INSTALLATION INSTRUCTIONS

FIGURE 36

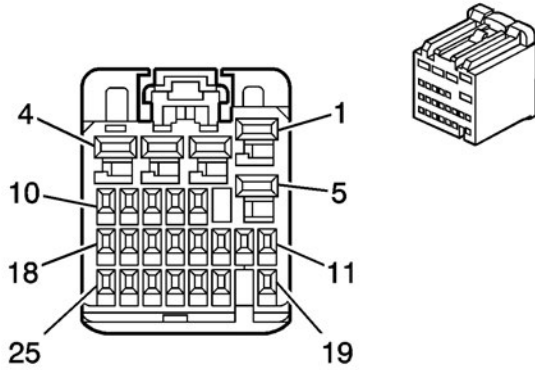

B. Cut terminal off pink ignition (+) wire of supplied Mirror Harness and splice to wire in Brown BCM X5 Connector Cavity 13. Figures 15 & 36.

69. Locate Ground Ring Terminal on black wire of supplied Mirror Harness and attach at lower knee bolster stud using supplied Ground Nut and a 10mm socket. Tighten to 4 N·m (36 lb in). Figure 37.

FIGURE 37



Install Supplied Rear View Mirror

70. Locate the supplied Inside Rearview Mirror (ISRVM.)
71. Insert the ISRVM connector into the supplied ISRVM until it clicks into place. Figure 38.

FIGURE 38

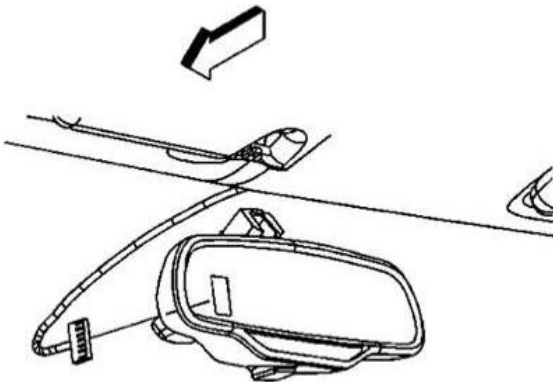

72. Slide supplied Mirror (2) onto the mounting tab (1). Figure 39.

FIGURE 39

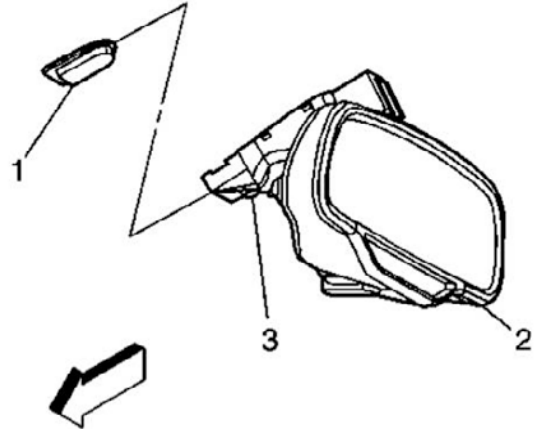

73. Tighten the Mirror screw (3) to 1.8 N·m (16 lb in). Figure 39.

74. Lower the front end of the Headlining Trim Panel.

75. Route the supplied Mirror Harness along the existing Headliner/A-Pillar wire harness.

76. Re-attach the ISRVM Wire Cover and base trim cover, if present. Figure 40.

FIGURE 40

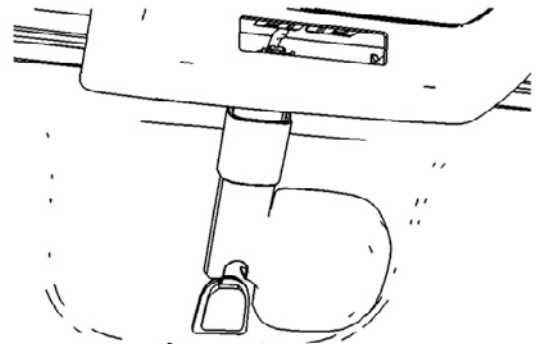

77. Re-engage the Roof Console Assembly (3) to the headliner. Figure 41.

FIGURE 41

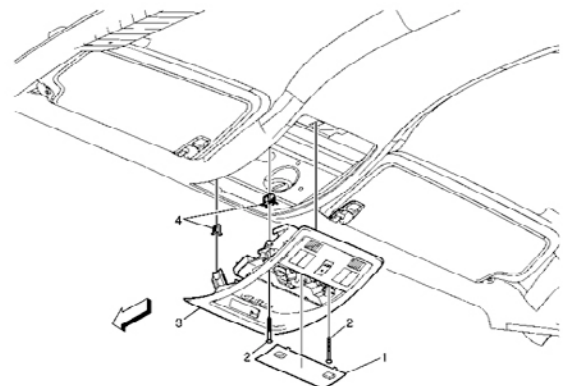

INSTALLATION INSTRUCTIONS

78. Re-install the two Roof Console Screws (2) into the Console Assembly (3), tighten the two Screws to 2 N·m (18 lb in). Figure 41.
79. Re-install the Front Overhead Console Lens (1). Figure 41.
80. Re-install the Driver's Side Sunshade Anchor (2), tighten the Screw (1) to 3 N·m (25 lb in). Figure 42.

FIGURE 42

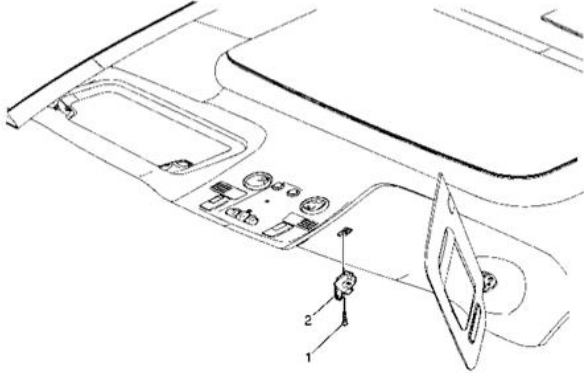

81. Re-install the Driver's Side Sunshade electrical connector, bracket (4) and assembly (3). Tighten the three Screws (2) to 6 N·m (53 lb in). Re-install the Driver's Side Sunshade Bracket Cover (1). Figure 43.

FIGURE 43

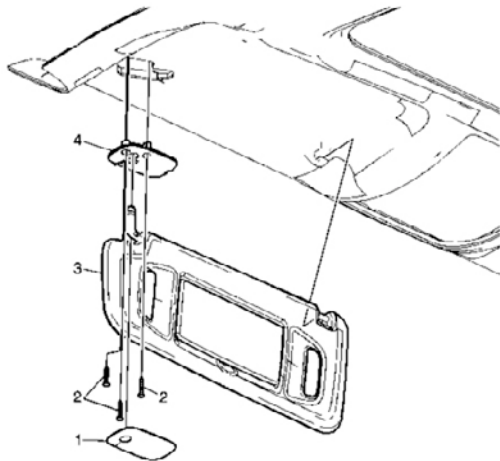

Install Chassis Harness

82. Locate the supplied Chassis Harness.
83. Route the grommet end of the Chassis Harness through the Driver's Side Wheel Housing and then through the opening you created in the Front-of-Dash. Figure 44.

FIGURE 44

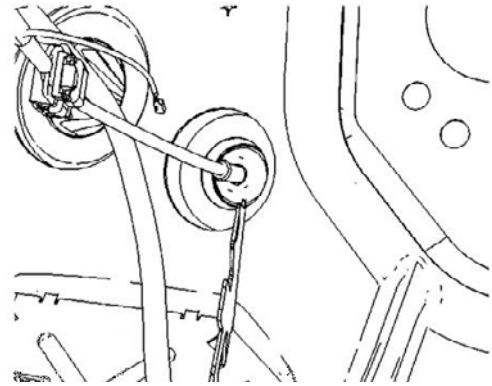

84. From the inside of the cab, pull the Chassis Harness through until the grommet is properly seated.
85. Remove the green lock tab from the Chassis Harness front connector by inserting the tip of Delphi Terminal Tool 12094429 or a small flat blade screwdriver between the lock tab and connector and prying the tab out. Figure 45.

FIGURE 45

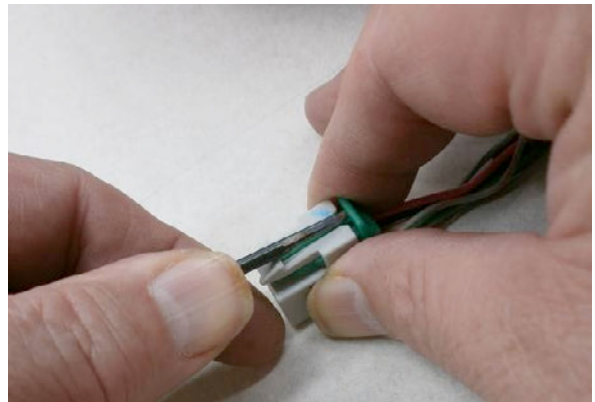

86. Connect the Chassis Harness to the Mirror Harness then reinstall the green lock tab. Secure both harnesses to vehicle wiring with supplied Wire Ties. Figure 46.

FIGURE 46

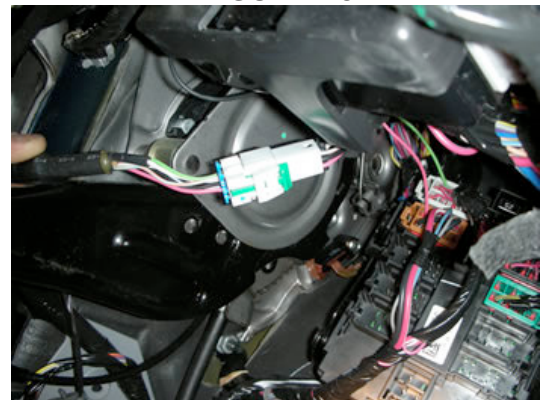

87. Install M-BEC into Support Bracket. Figure 47.

INSTALLATION INSTRUCTIONS

FIGURE 47

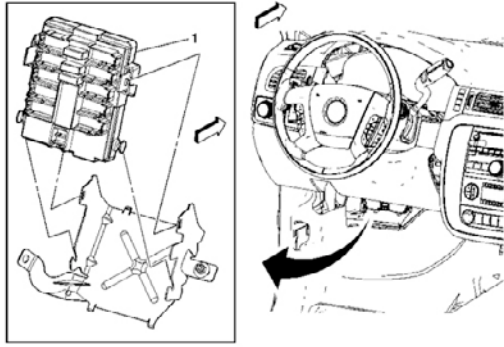
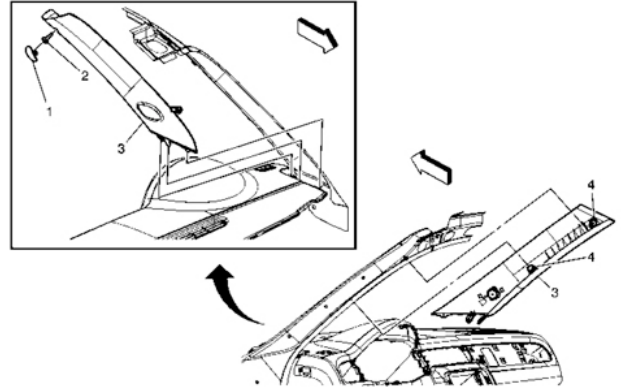

FIGURE 48



88. Install the M-BEC cover onto the M-BEC. Figure 15.
89. Raise vehicle on hoist to route the Chassis Harness.
90. Route the supplied Chassis Harness, working towards the rear of the vehicle, along the existing Chassis Harness, routing away from Body Mounts.
91. Connect the supplied Chassis Harness to the Camera Assembly Harness.
91. Secure the supplied Chassis Harness along the existing Chassis Harness using Wire Ties every 200mm (approximately 8"). Note: Depending on the vehicle wheelbase there may be excess length in the Chassis Harness. Loop, and secure with Wire Ties, any excess harness length along the Body Frame away from Mechanical areas.
92. Lower the truck.
93. Re-Install Rear License Plate, if necessary.
94. Connect the negative battery terminal. Tighten the negative cable nut to 5 N·m (44 lb in).
95. Test system functionality.
96. Re-install the Driver's Side Windshield Side Garnish Molding Assembly, secure the supplied mirror harness to existing harness using supplied Wire Ties, and reconnect the electrical connector (see Figure 24). Install and tighten the Screw (2) to 2 N·m (18 lb in). Install the Screw Cover (1). Figure 48

97. Re-install the Knee Bolster Assembly. Tighten Phillips Screws to 2 N·m (18 lb in). Re-install Parking Brake Release Handle and Bolt, tighten to 9 N·m (80 lb in). Figure 49.

FIGURE 49

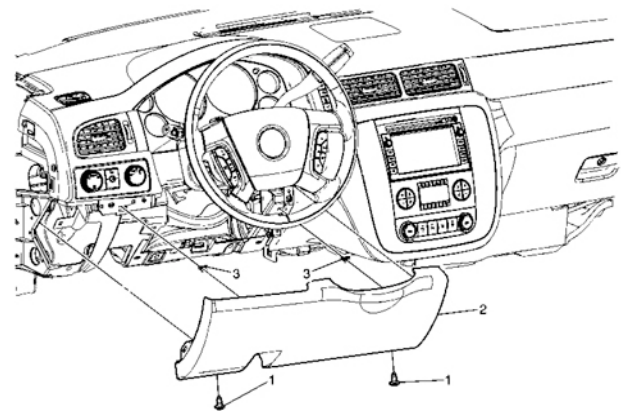

98. Re-install Instrument Panel Outer Trim Cover. See Figure 13.

Camera, Chassis, and Mirror Harness Pinouts (Reference only)

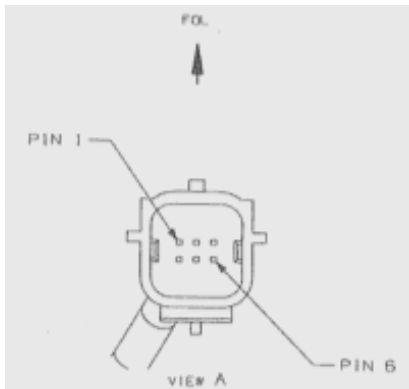

PIN #	FUNCTION	CAMERA HARNESS COLOR	CHASSIS HARNESS COLOR	MIRROR HARNESS COLOR
1	Video (+)	Yellow	White	Gray/ Dark Blue
2	Shield	White	Blue	White
3	Reverse	Blue	Green	Green
4	Video (-)	Brown	Brown	Gray/ Orange
5	Ground	Black	Black	Black
6	Ignition (+)	Red	Red	Pink